

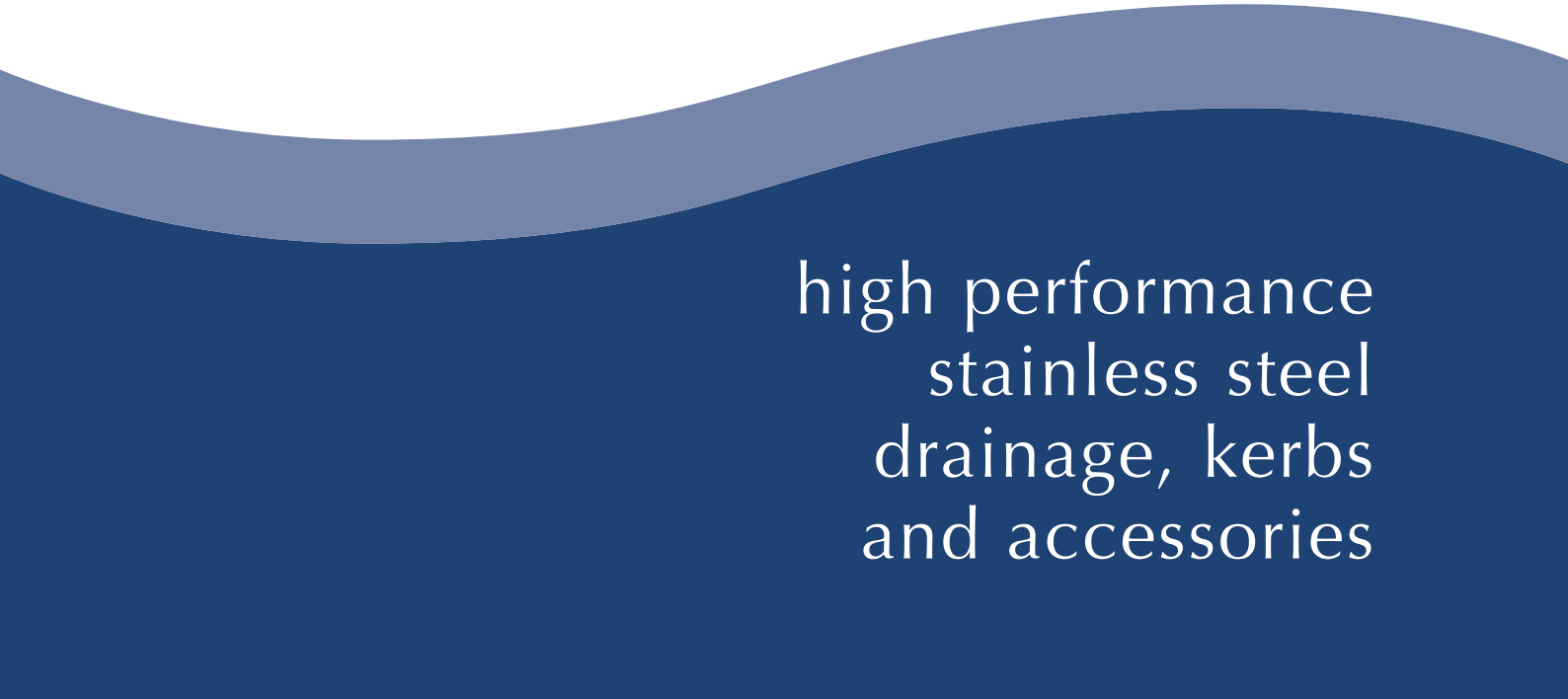

ASPEN

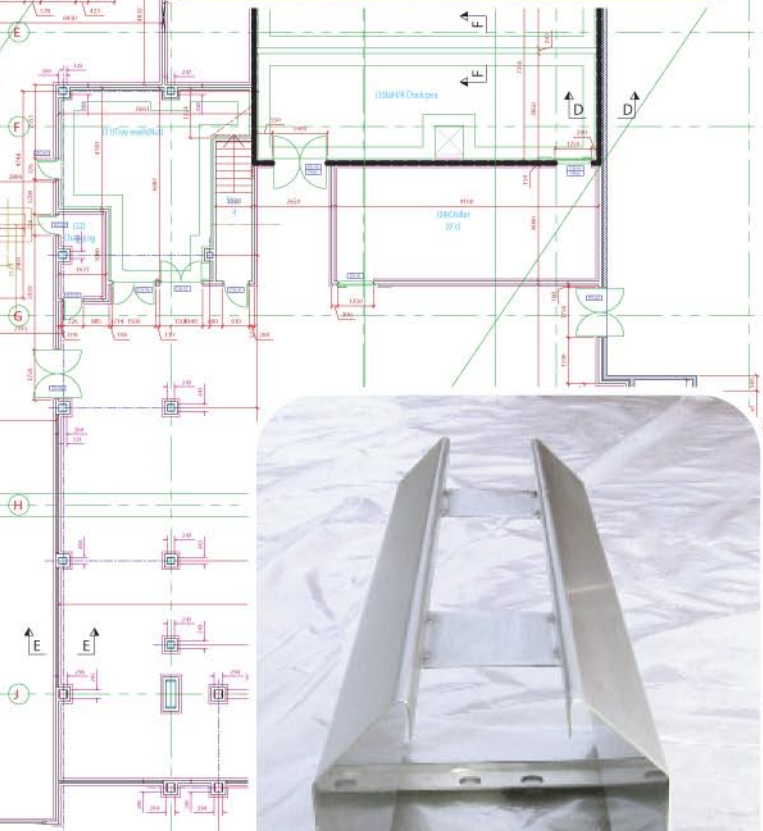

high performance  
stainless steel  
drainage, kerbs  
and accessories

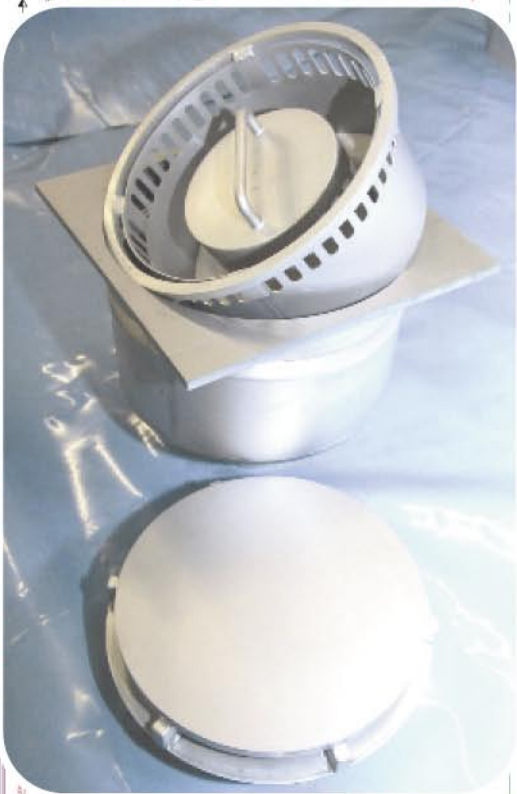

# Contents

**Welcome to the Aspen product brochure.**

- 1 INTRODUCTION
- 2 DRAIN CHANNELS - COLORADO/DAVOS
- 3 DRAIN CHANNEL OUTLETS - BANFF
- 4 DRAIN CHANNEL COVERS
- 5 SPOT GULLIES INTRODUCTION
- 6 TIEHACK RANGE OF GULLIES
- 7 VAIL, SUMMIT and DELTA GULLIES
- 8 SPECIALS
- 9 GULLY INSTALLATION
- 10 MANHOLES
- 11 STAINLESS STEEL KERBING/BIRDS BEAK
- 12 PROTECTION - BUMP RAILS, BOLLARDS AND GOAL POSTS
- 13 BALUSTRADE AND WALL CLADDING
- 14 ACCESSORIES AND OPTIONS
- 15 FLOORING SYSTEMS

## How to specify your drainage

This is a simple guide when deciding the type of drainage system you require.

**STEP 1 What is the maximum spillage in the location in litres per second?**

3 to 5 litres per second requires 110mm diameter outlet.  
5 to 9 litres per second requires 158mm diameter outlet.

**STEP 2 What type of traffic will go over the drainage?**

This will decide the strength of the drainage to be used. Foot only, pallet trucks, fork trucks?

**STEP 3 What grade of stainless steel should be specified?**

Type 304 is general grade, 316 is most corrosion resistant.

The surrounding environment requires consideration, including the type of products being processed and the type and concentration of cleaning materials.

**STEP 4 Check the levels of any adjoining manholes or outlet pipes to ensure you choose the correct type and direction of outlet.**



## Introduction

### Values - The foundation of our business

Our business has developed from a family culture to one that embraces modern management techniques and expects contribution from every member of our team.

Energy, creativity and ambition are the mainstays of our rapidly expanding organisation. Ever responsive to our clients needs, we pride ourselves upon a combination of technical excellence coupled to an honest and committed service delivery.

Consequently, our professional teams are highly valued and encouraged to play the widest possible role in the development of the business.



The Aspen range of high quality long term durable specialist drainage, wall kerbing and diverse product list that constitutes the Aspen range are entirely designed and manufactured in the U.K

Our production facilities include state of the art manufacturing and machinery equipment and work practices.

All of our employees are qualified in all aspects of factory and site work.

We pride ourselves in following projects through from conception to installation.

# Design, manufacture and install

Our design teams are constantly working alongside Designers, Engineers, Architects and Clients to enable our Company to provide the best 'Fit for Purpose' system to suit today's environment.

*All stainless steel materials conform to Euro norms - EN10088: Part 2: 1995*

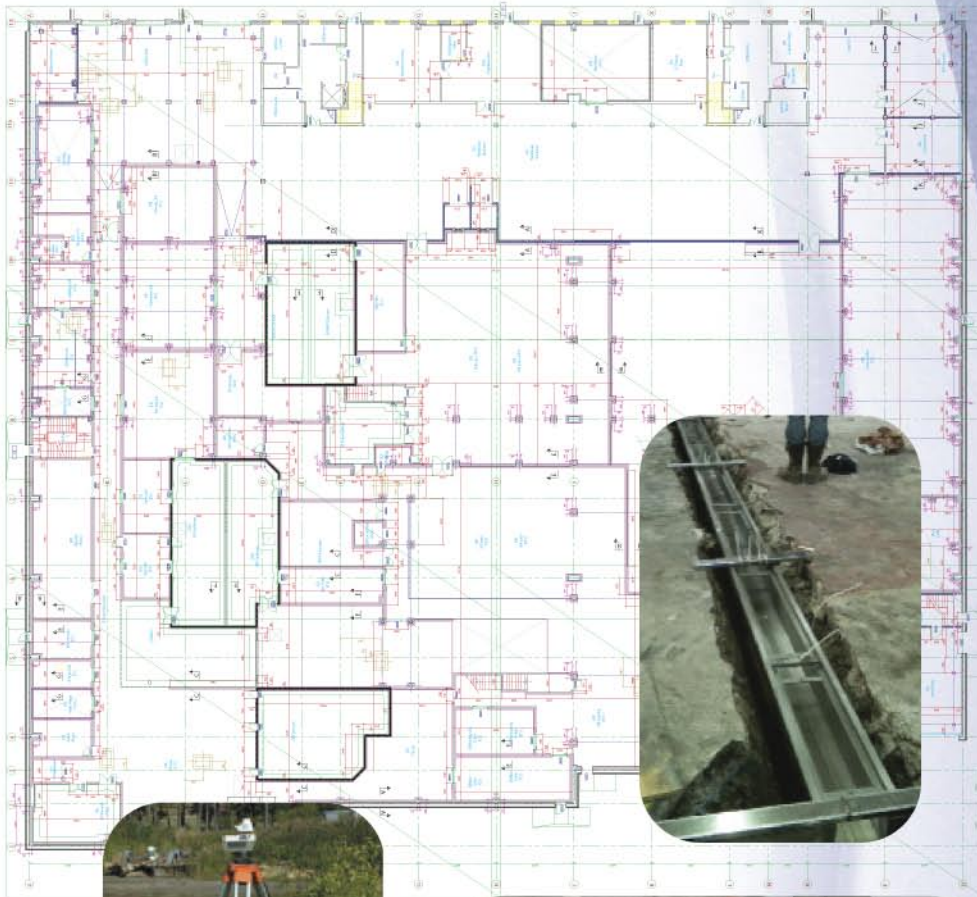



# Drainage Channels

## The Colorado heavy duty drainage channel

The Colorado drainage design is one of the most substantial and robust channel units in the Aspen range.

It is specifically designed to withstand the rigors and demands of today's heavy industrial processes and conform to the ever increasing standards of hygiene.

The double stainless steel box section rebate reinforcement provides increased strength at critical locations. A perforated stainless steel strip is fixed along the channel outer perimeter to assist in achieving maximum bond characteristics with interfacing floor finishes or expansion jointing mastic.

The channel body is manufactured from 2mm thick type 304 stainless steel sheet.

The channel covers are separated using a welded 5mm bar as divisions to prevent the cover from moving if any adjacent covers are removed. Such cross bracing also significantly increases the structural strength of the channel unit.

Aspen drainage channels are designed and manufactured with a standard built in fall of 1-150 to assist the self-draining process and is secured by concrete ties welded to the drain sides or mechanically fixed when being installed into certain ceramic floor tiling systems.

The channels are supplied in 5 metre lengths from the factory and then fully site welded, cleaned and polished.

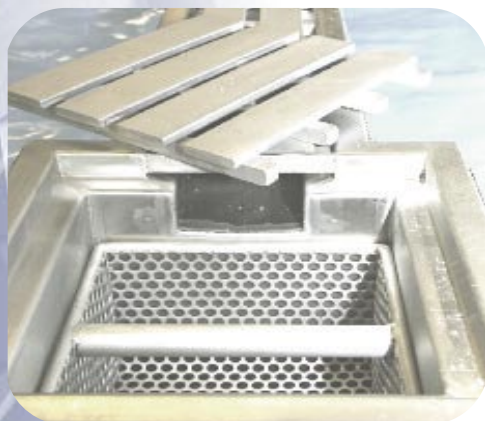

# Aspen Drain Channel Profiles

Ref: Colorado 100

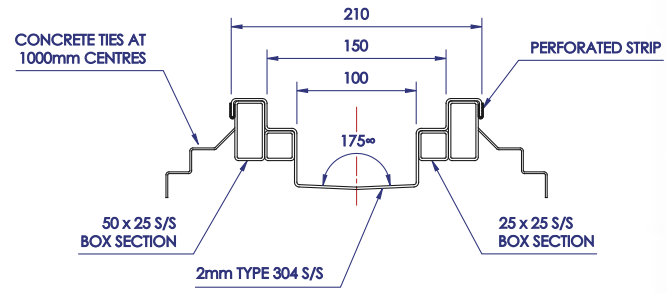

Ref: Colorado 170

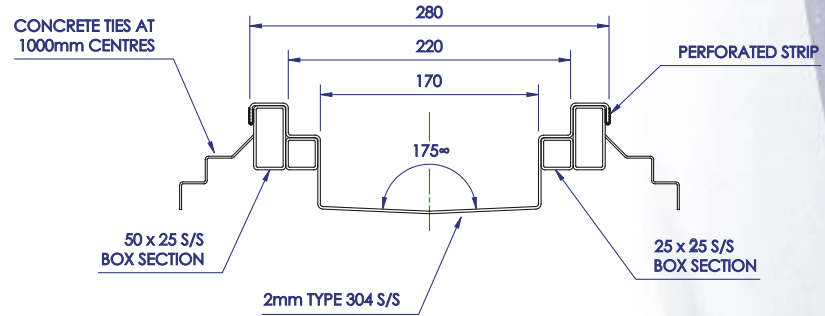

Ref: Davos Plus 100

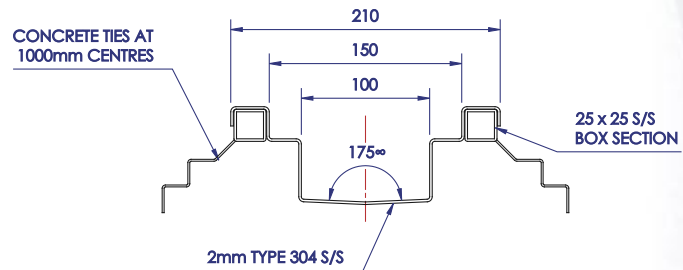

Ref: Davos Plus 170

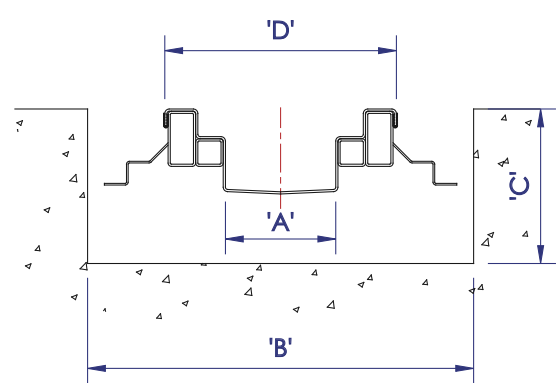
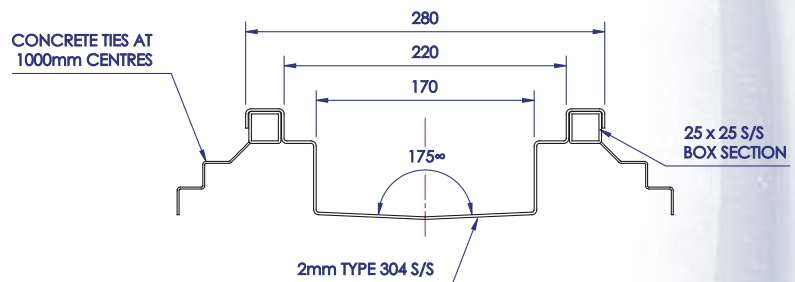

URAGARD SEAMLESS RESIN SCREED SYSTEM

DRAIN WIDTH ('A')	DIMENSION 'B'	DIMENSION 'C'	DIMENSION 'D'
100mm	350mm	CHANNEL DEPTH +65mm	210mm
170mm	420mm		280mm

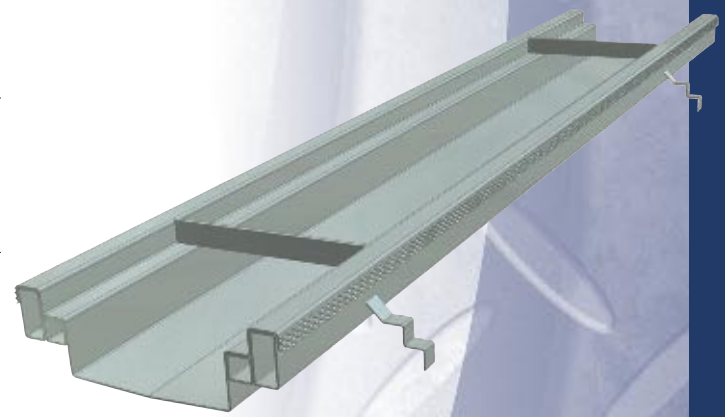

Bespoke sizes also available

# Aspen drainage system

## Stainless Steel Drainage Channel

*Installation method for Seamless Resin Screed Floor Specification*

- 1 Ensure stainless steel drainage outlet is manufactured to the same O/D as the drain, or to suit the internal dimensions of the connector.
- 2 Ensure the drain top is positioned at the correct level to allow the channel outlet to be positioned above, giving the correct structural concrete slab level in relation to on the channel top surface. (Allow for connector).
- 3 If the channel is to be fitted into a concrete slab recess or cut-out, ensure the cut-out or recess dimensions include a margin approximately 100 to 125mm wide on all perimeters and beneath invert levels of the channel.
- 4 Drill out for and fit dowels in the vertical sides of the concrete cut-out at 1000mm centres.
- 5 The maximum length of Aspen channel delivery is approximately 5m longer channels are lowered into the recess/cut-out in sections, butted together, levelled and site welded into a continuous length before final securing.
- 6 **Secure Aspen channels to the structural concrete floor slab to prevent 'floating' during infill process. Ensure the top of the channel is level with the concrete slab prior to any floor finishes being applied.**
- 7 Method of securing is as follows:-
  - Secure 50 x 50 x 1200mm stainless steel box section across channel width at approximately 2000mm centres. Method of securing can be by electrical tie-wraps.
  - 'Hang' channel into recess/cut-out from the battens.
  - Use packing if necessary to give correct channel level in relation to finished concrete floor level, taking into account floor finishing screed thickness. Channel is installed at finished concrete floor level. (Unless specially directed otherwise).
  - When unit is in position, secure battens using Hilti fixings or bags of aggregate or sand to prevent channel 'floating' when infilling with concrete.
- 8 Infill around the channel using C35 concrete or co-polymer modified fine screed where appropriate.
- 9 NB - Using 50 x 25mm rough cut timber, create a 50 x 25 toe-in rebate along the interface with the channel perimeter for later application of resin based screed.
- 10 Upon cure remove Hilti fixing etc. and timber battens.

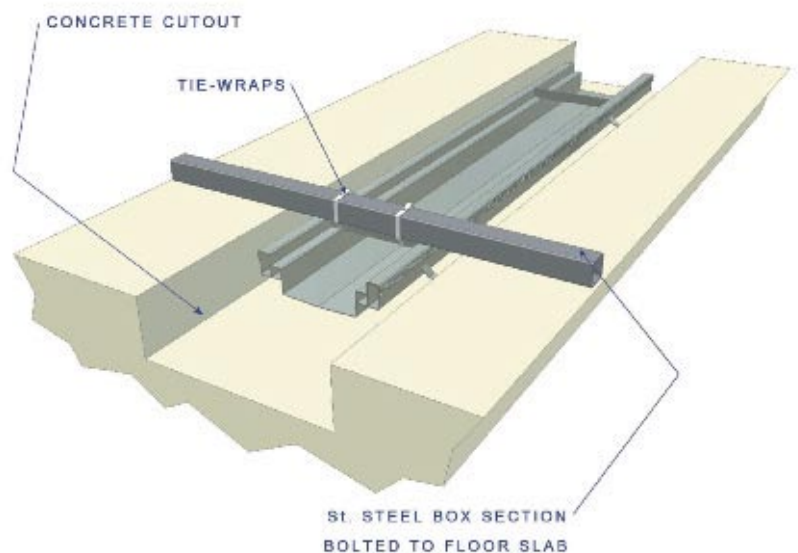



# Drain channel outlets

The Aspen range of channels can be matched with a various range of drain channel outlets. The drain channel outlet offers a sealed connection between the sub terrain drainage pipe and the aspen channel. This outlet also incorporates a minimum 50mm water trap with easy access for rodding and a removable trash basket to prevent factory debris getting through to the effluent.

The linear position of the outlet can be pre determined along the length of the channel or be placed at one or both ends of a channel.

On most installations our site teams would site check outlet positions before manufacture commences.

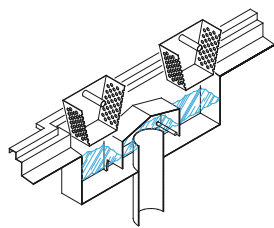

## Banff Channel Outlets (Bottom)

Ref: **B.O.C. 100** Outlet - 6 LTS per second  
**B.O.C. 150** Outlet - 10 LTS per second  
*Can be placed at any point along the channels length.*

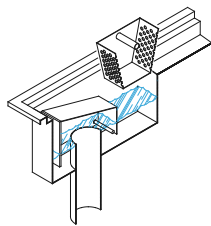

Ref: **B.O.E. 100** Outlet - 6 LTS per second  
**B.O.E. 150** Outlet - 10 LTS per second  
*Can be placed at the end of each channel.*

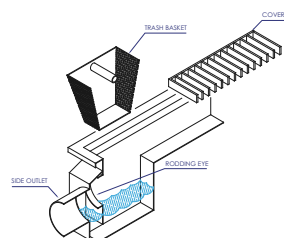

## Diamond Channel Outlets (Side Outlet)

Ref: **DO 1 100** Outlet 6 LTS per second  
**DO 3 150** Outlet 10 LTS per second  
*Can be placed at any point along the channels length.*  
*Standard spot gullies (see section 6,7,8) can be used along a channels length as a trapped outlet*

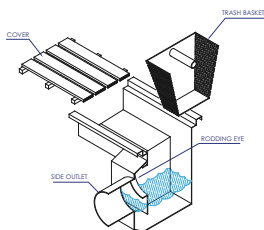

Ref: **DO2 100** Outlet 6 LTS per second  
**DO4 150** Outlet 10 LTS per second  
*Can be placed at any point along the channels length.*

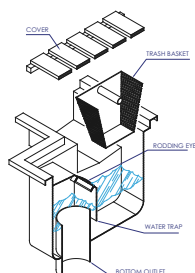

## Diamond Channel Outlets (Bottom Outlet)

Ref: **DO 5 100** Outlet 6 LTS per second  
**DO 6 150** Outlet 10 LTS per second  
*Can be placed at any point along the channels length.*

# Drain Connections

The Aspen range of drainage is sized to suit plastic connectors.



**Stainless steel drainage pipes**



**Cross section of typical underground connection**

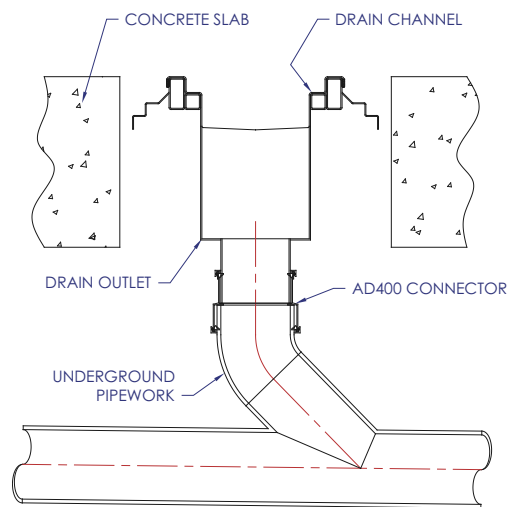

We offer a supply, or supply and installation service for stainless steel underground waste pipe to complete the drainage package.

# Channel Covers

## Aspen Drain Channel Covers

Choosing the correct drainage channel cover is as important as any other aspect of the channel specification, if providing the most effective drainage installation is to be achieved.

Included within the Aspen range are a wide variety of drainage channel cover plates to address the various influencing criteria. Issues such as anti-slip profile for safety underfoot, ease of clean, cover weight, load capacity, drainage facility and appearance, must all be addressed to insure a successful installation.



The Aspen range of drainage channel covers are manufactured to fit the total Aspen range of channel profiles. (Colorado/Davos Plus). All cover designs can be manufactured from type 304 or 316 stainless steel.

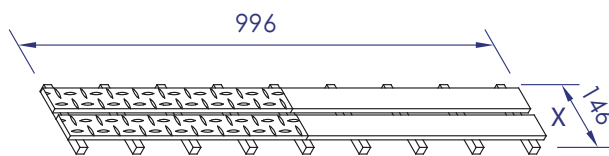

Type	Dimension X	Weight/mtr
CC100B	146mm	10kg
CC100A	146mm	8kg

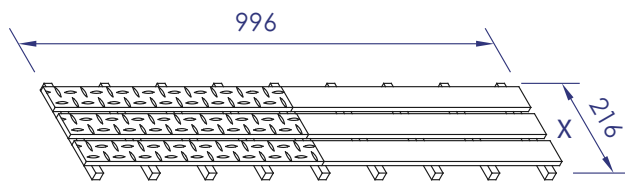

Type	Dimension X	Weight/mtr
CC170B	216mm	16kg
CC170A	216mm	14kg

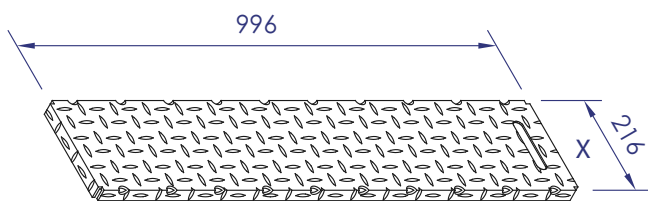

Type	Dimension X	Weight/mtr
CC100C	146mm	6kg
CC170C	216mm	8kg

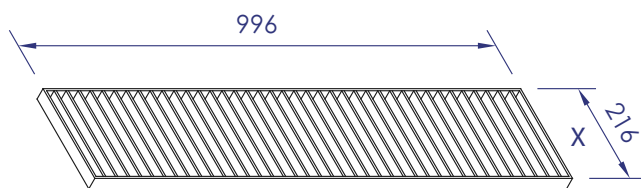

Type	Dimension X	Weight/mtr
CC100D	146mm	4kg
CC170D	216mm	6kg

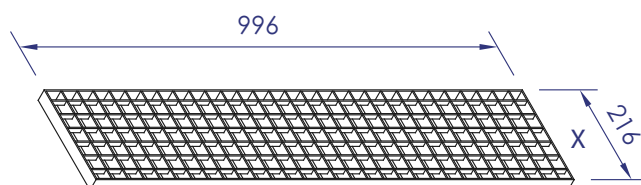

Type	Dimension X	Weight/mtr
CC100E	146mm	8kg
CC170E	216mm	10kg



# ASPEN Spot Gullies

The Aspen Spot Gully range has been designed for use in all areas of today's modern, hygienic environment.

All Aspen Spot Gullies have been designed to compliment The John Lord ceramic and polyurethane flooring systems. Each gully incorporates water trap, trash basket and cover and have a wide range of options to suit customer needs.

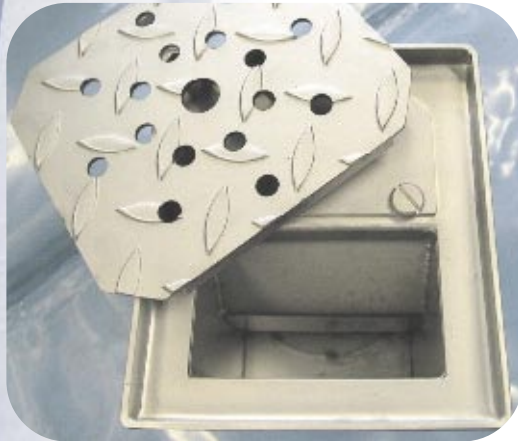
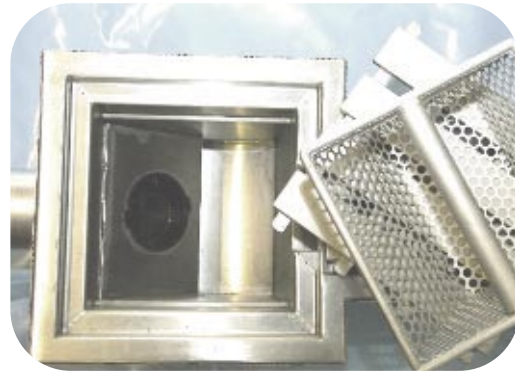
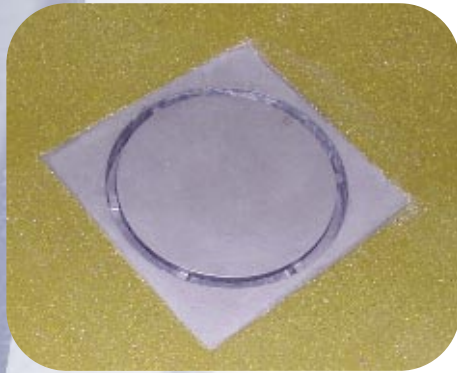

# Tiehack Gullies – Heavy Duty

The most popular and robust gully in the Aspen range.

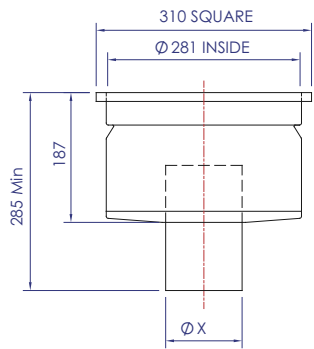

## STANDARD

- Ref:-  
**TG2 - 110** Outlet  
**TG3 - 158** Outlet

Complete with water trap and trash basket

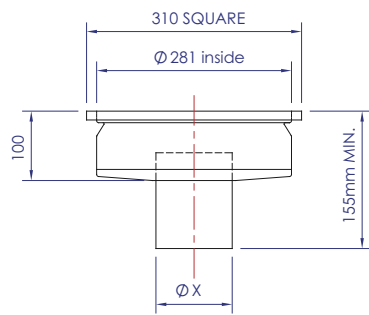
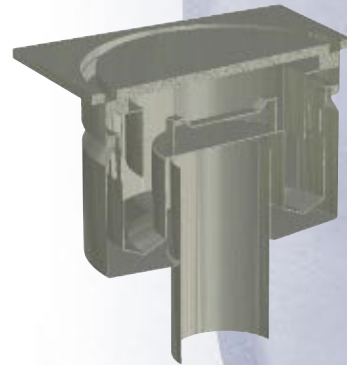

## PANCAKE

- Ref:-  
**PG1 - 110** Outlet  
**PG2 - 158** Outlet

Complete with water trap and trash basket

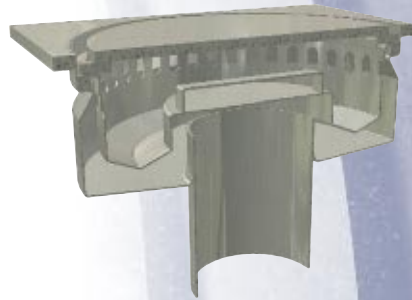

## SIDE OUTLET

- Ref:-  
**TG2SO - 110** Outlet  
**TG2SO - 158** Outlet

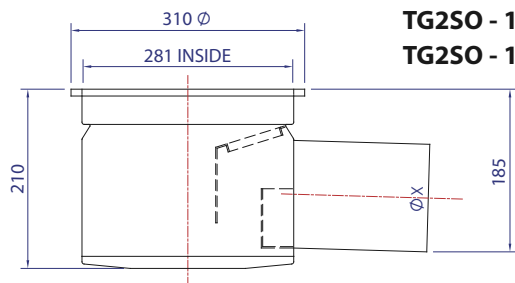

Complete with water trap and trash basket

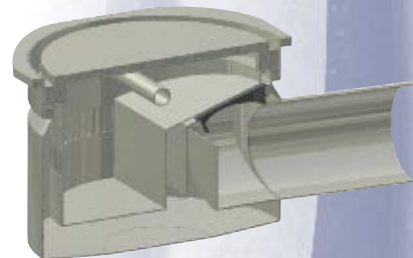

for round top plate options see Section 14

# Vail – Medium to Heavy Duty

Specifically designed with a side outlet facility for use in areas where shallow inverts are present.

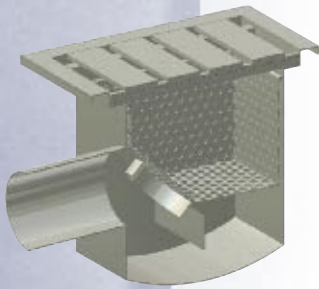

- VG1 - 110** Outlet
- VG2 - 158** Outlet

Complete with water trap and trash basket.

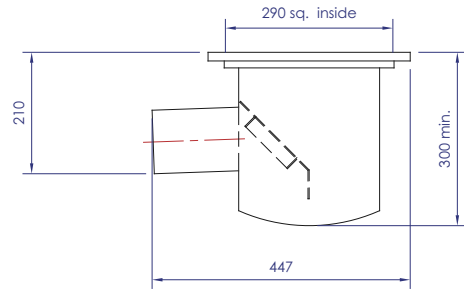

# Summit – Medium to Heavy Duty



- SR1** Round Top 110 Outlet
- SS1** Square Top 110 Outlet
- SR2** Round Top 158 Outlet
- SS2** Square Top 158 Outlet
- SR1DB** Round Top 110 Outlet
- SS1DB** Square Top 110 Outlet

Complete with water trap and trash basket.

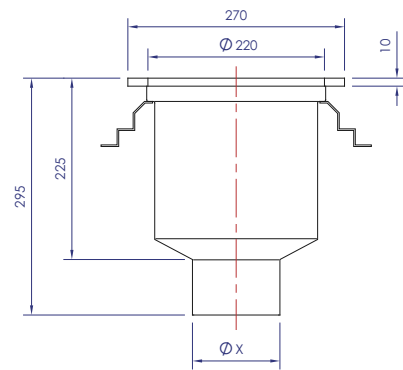

# Delta – Light Duty

Designed to be installed close to wall or kerb in low traffic areas to facilitate sink or condense waste and low volume floor spillage.

- DG1 - 110** Outlet (Bottom)
  - DG2 - 110** Outlet (Side)
- Complete with water trap.

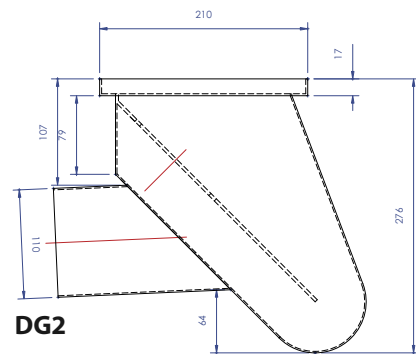
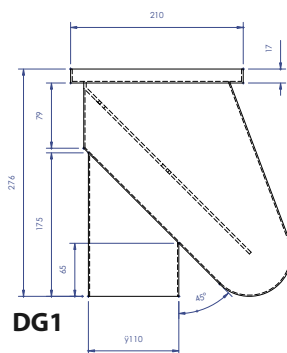
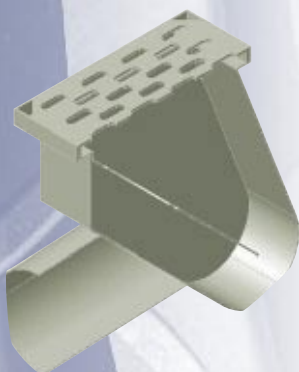

for more options see Section 14



# Specials

We design specials for individual customer specific requirements.

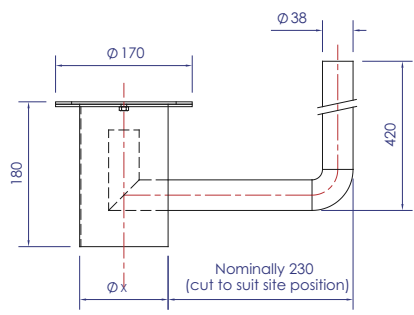

## WHISTLER - LIGHT DUTY

Designed for sink and condense waste.

**W1 - 110** Outlet with sink waste back inlet

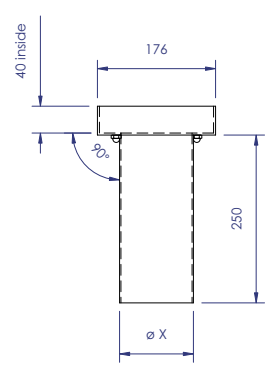

## RODDING EYE ACCESS POINTS

**SRE1** 110 Outlet (Straight)  
**SRE2** 158 Outlet (Straight)

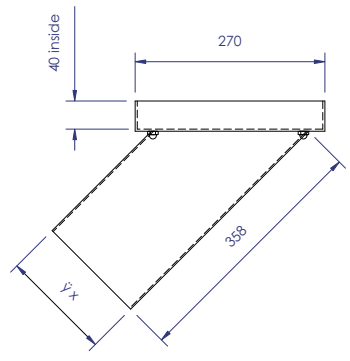

**ARE3** 110 Outlet (45)  
**ARE4** 158 Outlet (45)

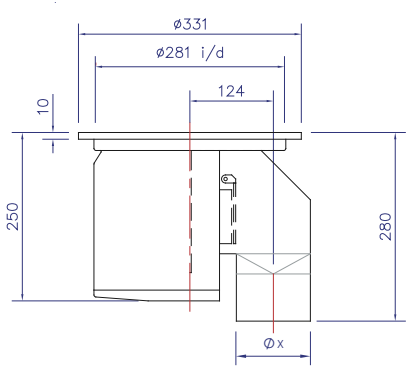

## ANTI BACKFLOW GULLY - LIGHT DUTY

**AB1 - 110** Outlet  
**AB2 - 158** Outlet

Complete with water trap and trash basket.

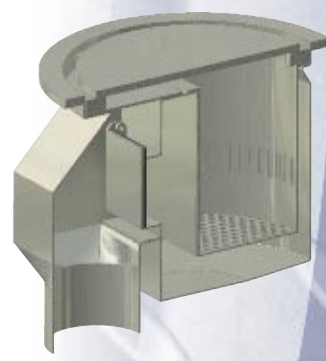

Available with side outlet

for more options see Section 14

# Gully Installation

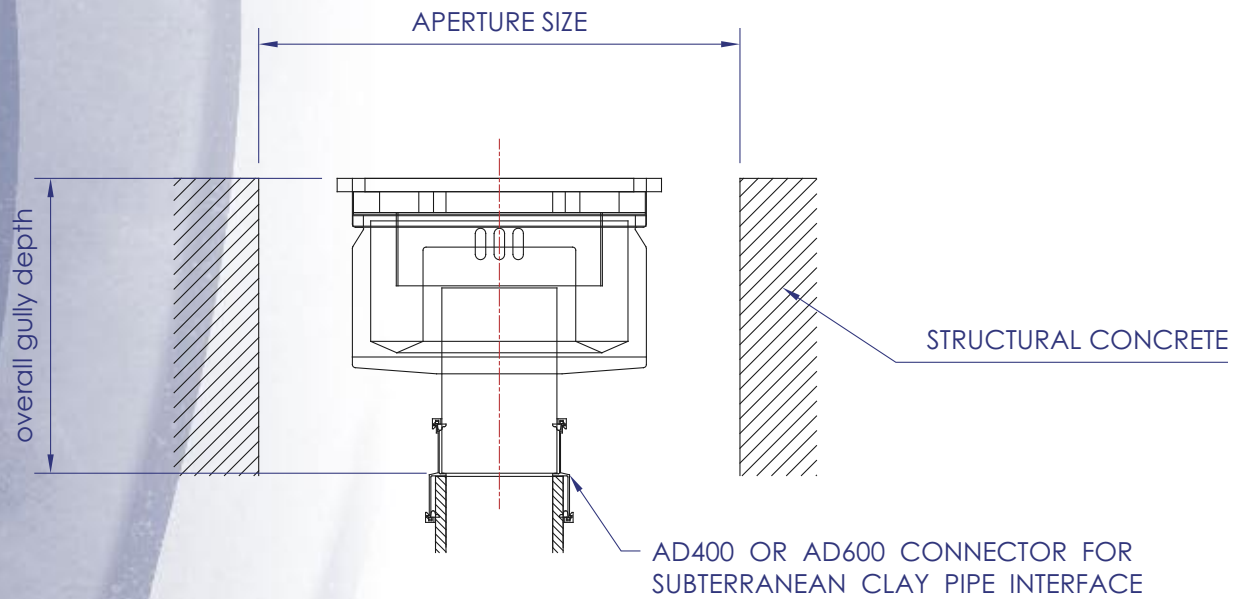

Gully Type	Aperture Size	Minimum Gully Depth	Flow Rate 100 Ø	Flow Rate 150 Ø
SUMMITT (SR1)	420mm Square	290mm	4.0 Ltr/Sec	6.7 Ltr/Sec
DELTA (DG1)	320mm Square	230mm	3.0 Ltr/Sec	N/A
DELTA (DG2)	320mm Square	250mm	3.0 Ltr/Sec	N/A
PANCAKE (PG1)	460mm Square	180mm	3.5 Ltr/Sec	N/A
TIEHACK (TG2)	460mm Square	250mm	4.0 Ltr/Sec	9.0 Ltr/Sec
TIEHACK (TG3)	500mm Square	290mm	TBC	TBC
VAIL (VG1)	500mm Square	Side Outlet	5.0 Ltr/Sec	10 Ltr/Sec

This chart gives a summary of the concrete openings required for the various gully types. Individual dimensions can be obtained from our technical office.

# Manholes - Cover and Frame

## Double sealed and locking

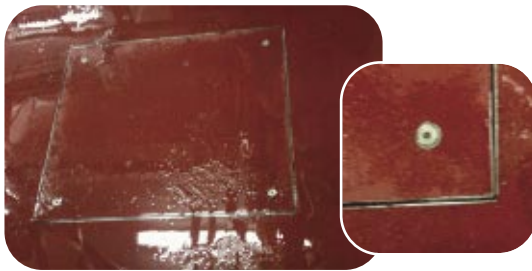
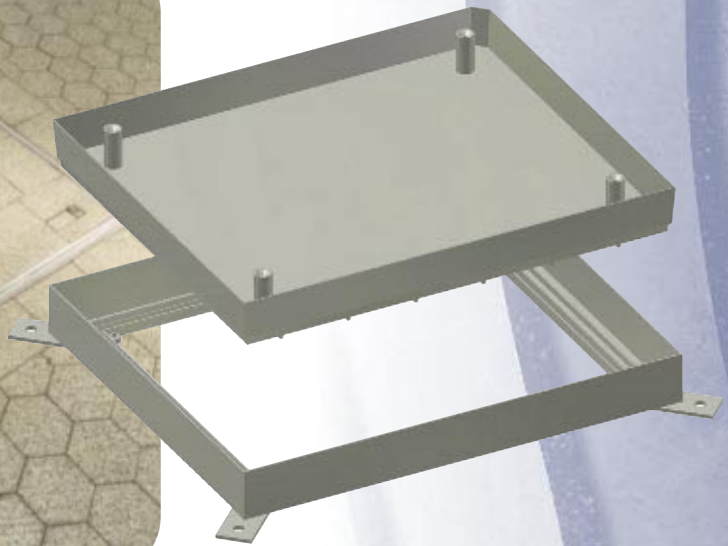
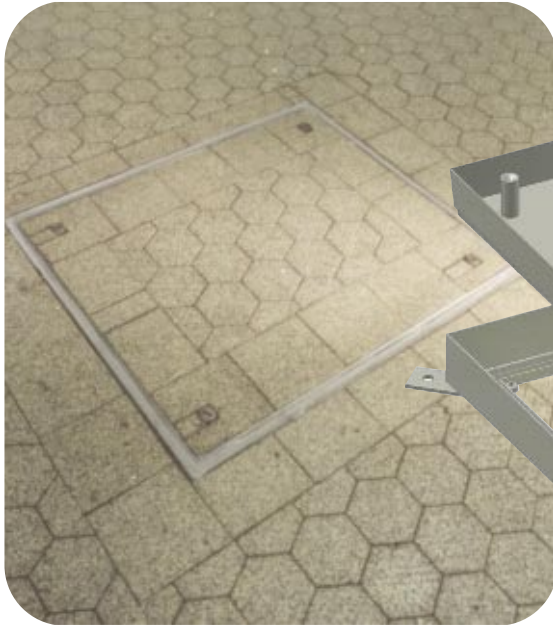

### Ref: NR1, NR2, NR3, NR4, NR5

Aspen offer three standard sizes of manhole covers and frames, but can manufacture bespoke units to suit any sizes.

The Norquay provides double sealed and locking manhole access, suitable for use in food environments and can be filled with the relevant floor finish to compliment and blend with the surrounding finished floor area.

The Norquay is a robust unit with internal and external cross bracing to withstand typical factory traffic.

All external and exposed surfaces are manufactured from type 304 stainless steel.

TYPE	WIDTH	LENGTH	DEPTH	MAX LOAD
NR1	550	650	72	250 / KN
NR2	650	750	72	250 / KN
NR3	750	850	72	250 / KN
NR4	600	600	72	250 / KN
NR5	1000	1000	72	150 / KN



# Stainless Steel Wall Support Kerbing

The Aspen stainless steel wall support kerbing provides a hygienic and low maintenance interface between wall and floor finish. It also provides protection from general factory traffic.

Each room layout is detailed to determine room shape, size, door openings and drainage requirement. We then provide detailed C.A.D drawings to our clients showing exact and detailed design proposals. Once approved, the wall support kerbing is then manufactured and delivered ready for assembly on site.

The wall support kerbing is levelled, mechanically fixed to the floor slab and then filled with a C30 or C35 semi-dry concrete. After initial cure the areas become immediately available for panel and floor finish contractors.

In cold store areas and against block walls a clip on version of the wall support kerbing is used, continuing the profile and protection throughout.

A galvanised single skin is installed, concrete filled and then finished with the matching stainless steel profile.

There are various profiles of wall support systems which all have specific applications. All ends, tees and corner units are fully welded, cleaned and polished to a high standard at our factory.

All profiles are manufactured from 1.5mm type 316 stainless steel sheets and can be manufactured to suit any width of insulated panel.

*Birds Beak & Cove*

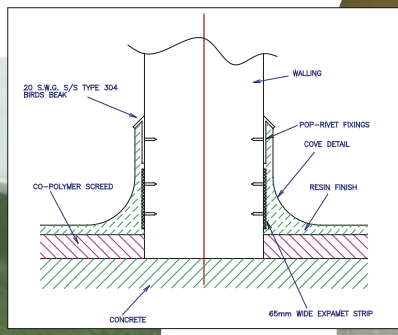
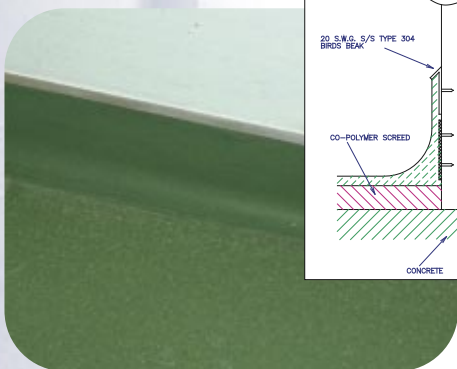

*Heavy Duty Kerb with Concrete*

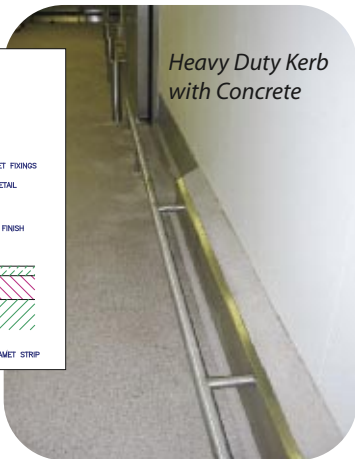

*Stainless Steel Kerb*



*Rendered Concrete Kerb*

# The Aspen Kerbing Range

## KC RANGE

This profile is the most common kerb profile, used with polyurethane floors or similar.

Ref:

**KC1 - Double sided internal wall kerb**

**KC2 - Single sided kerb**

**KC3 - Clip on kerb**

**KC4 - Double sided external wall kerb**



REF.: KC1

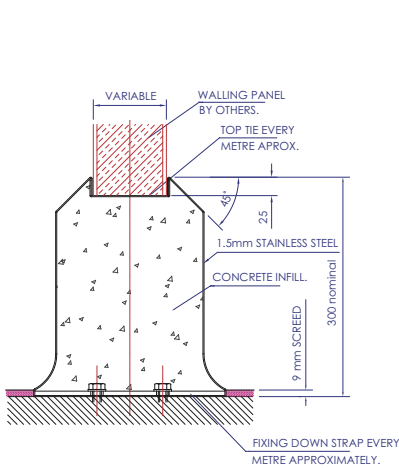

REF.: KC2

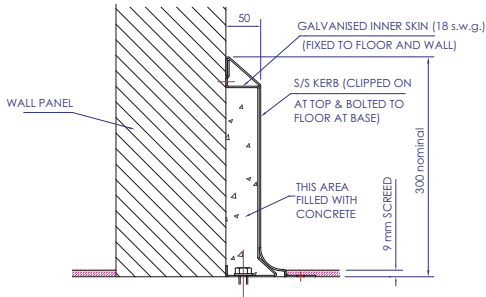
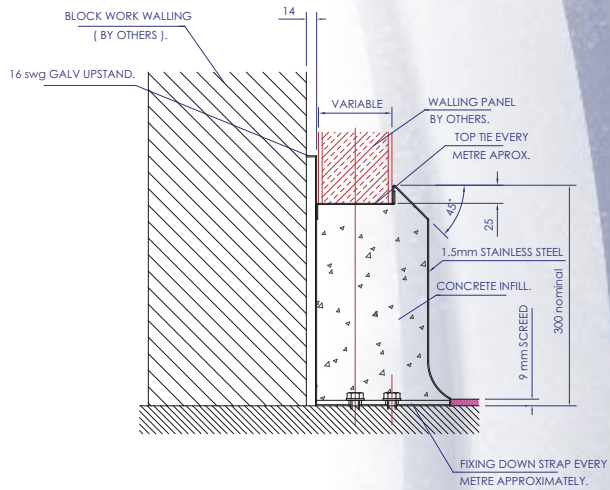

REF.: KC3

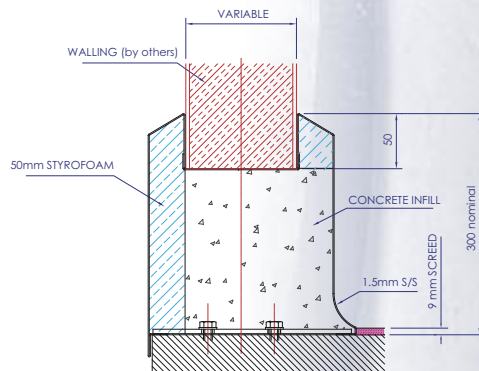

REF.: KC4

# The Aspen Kerbing Range

## KB RANGE

This profile is used when a full screed or ceramic tiling is required at the kerb edge.

Ref:

**KB1 - Double sided internal wall kerb**

**KB2 - Single sided kerb**

**KB3 - Clip on kerb**

**KB4 - Double sided external wall kerb**

REF.: KB1

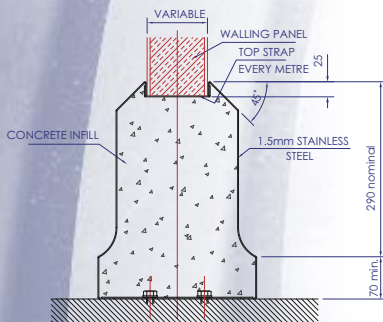

REF.: KB2

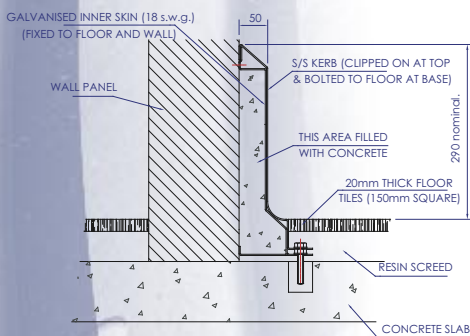
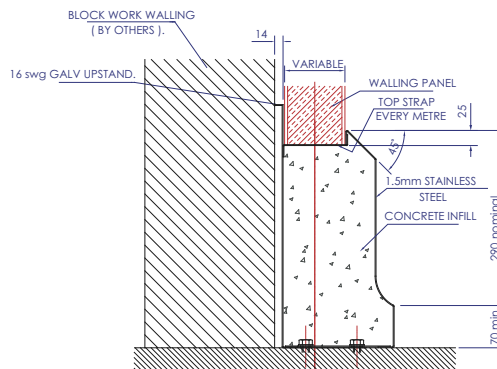

REF.: KB3

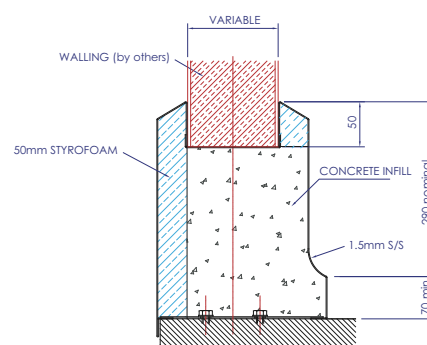

REF.: KB4



# The Aspen Kerbing Range

## KA RANGE

This profile is used on existing concrete floor slabs where any uneven finish/existing falls can be compensated with a resin based cove.

Ref:

**KA1 - Double sided internal wall kerb**

**KA2 - Single sided kerb**

**KA3 - Clip on kerb**

**KA4 - Double sided external wall kerb**

REF.: KA1

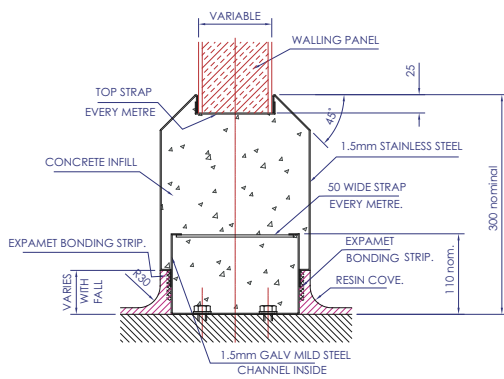

REF.: KA2

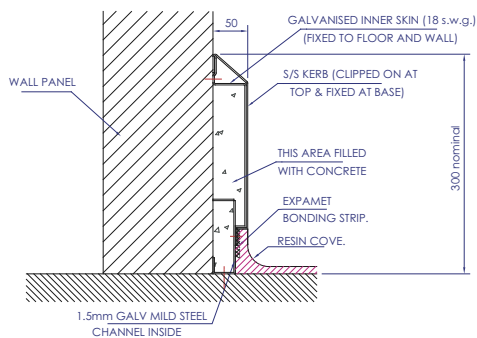
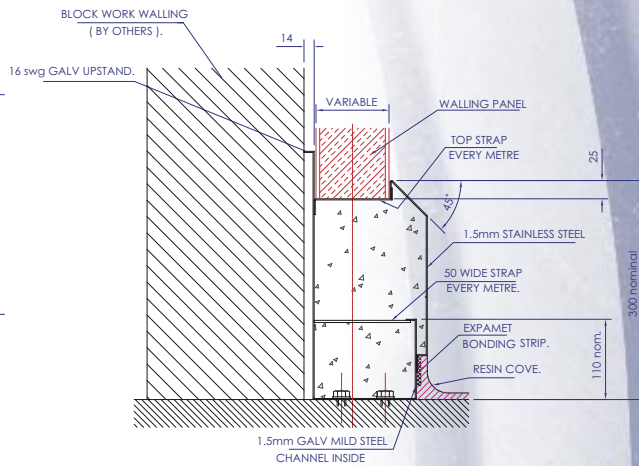

REF.: KA3

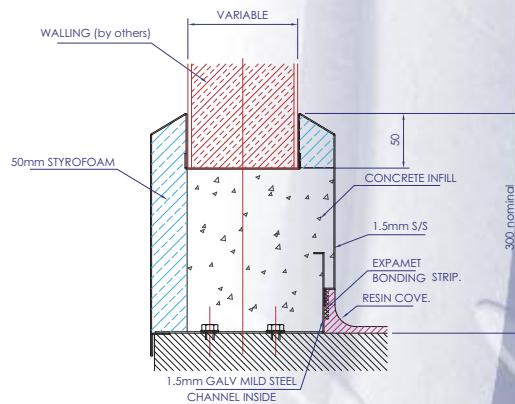

REF.: KA4

## Protection

### **BUMP RAILS**

Additional kerb protection for the perimeter of each room. Fitted directly to the stainless steel kerb, anchor fixed to the floor or core drilled and resin fixed to floor.

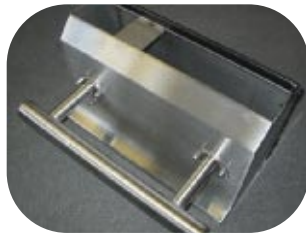

### **BOLLARDS**

Concrete filled stainless steel tube core drilled and resin fixed to floor for protection of doorways.



### **GOALPOSTS**

Heavy duty galvanised steel or stainless steel tube for protection around loading bay doors.



# Ballustrade and Wall Cladding

## BALLUSTRADE/STAIRCASE

We can offer various designs of standard and bespoke staircases, handrails and ballustrades



## WALL CLADDING



Engine Swirl  
Stainless Steel  
Cladding



Aluminium Cladding



Plain Stainless Steel Sheet Cladding



# Options and Accessories

- Alternative round top plate for Tiehack gullies



- Tiehack membrane disc

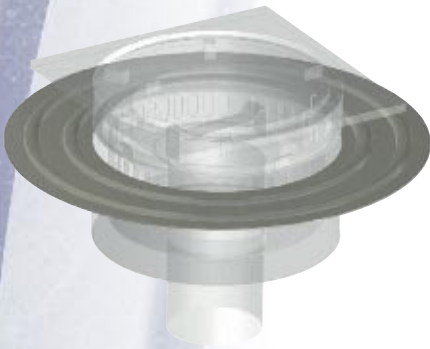

- Ladder type Tiehack lid



- Grid type Tiehack lid



- Tiehack lid lifting tool

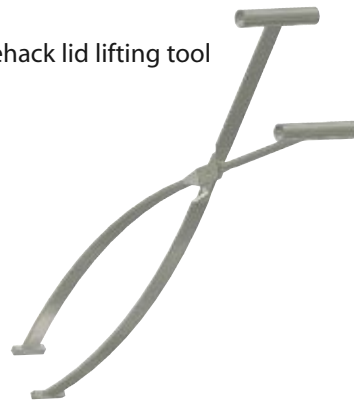

- Stainless Steel Durbar Tiles



- Stainless Steel Smooth Tiles



# Options and Accessories

- 90 Bend to convert Tiehack gully to side outlet

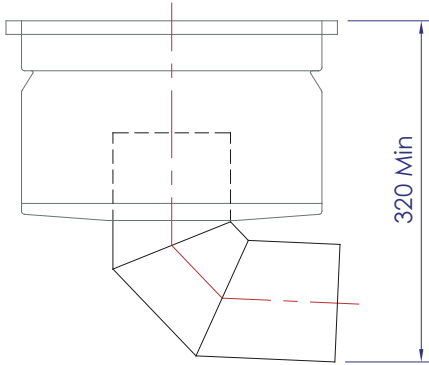

OPTIONAL BEND OUTLET

- Locking Tiehack lid

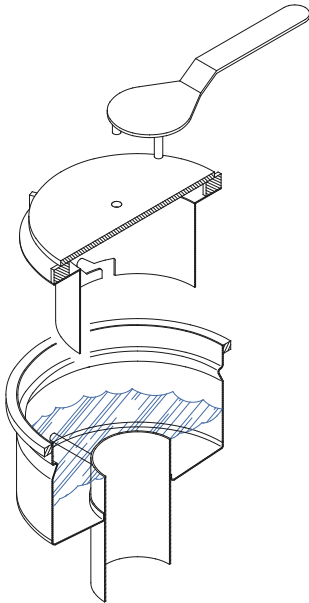

- Variable mesh size for trash baskets

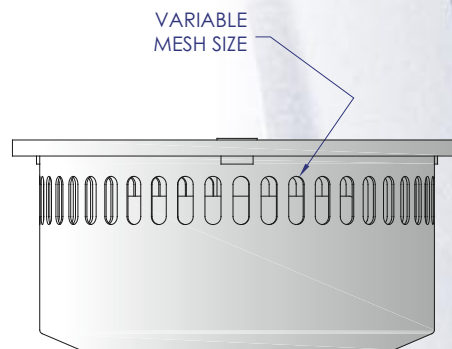

- Typical Back Inlet Connection

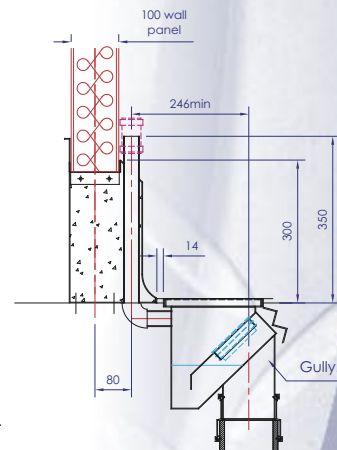
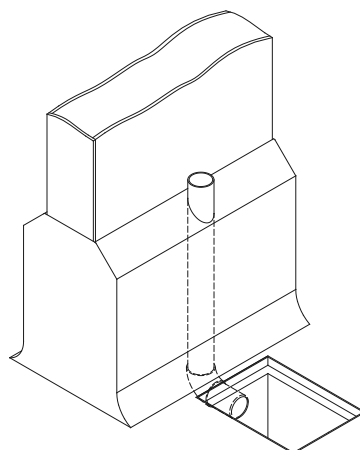

# Uragard HT polyurethane flooring

Confirming the commitment to Polyurethane resin technology, John Lord offers a three Generation range of Uragard HT products.

- Uragard HT100** Heavy duty, flexible screed designed solely for freezer temperature environments.
- Uragard HT110W** Heavy duty, general purpose screed, fast cure, medium anti-slip profile, medium flexibility.
- Uragard ZO** Anti-static heavy duty Terrazzo finish, electronically conductive screed.
- Uragard HT120W** Optimum performance range of screeds with various anti-slip profiles and textures.
- Uragard HT62W**
- Uragard A-S**





# Vibrogard Industrial Ceramic Floor Tiling System

**Design Concept** The principle behind the VIBROGARD concept is to produce independent panels of floor finish with extremely high, flexural and tensile strength. These panels can be bonded to, or isolated from the structural substrate and are bounded by designed flexible joints.

**Bedding and Bonding** The VIBROGARD system relies on a 'thick bed' method of installation. Bedding medium is layed to a minimum 40mm thickness when bonded and 50mm when isolated. The mixed material is layed to desired levels in a semi-dry consistency incorporating structural steel mesh fabric to B196 or random fibres and then is mechanically compacted to achieve maximum density.

**Alternatives** As an economical alternative to the range of top quality hexagonal tiles, John Lord offer a limited number of carefully selected rectangular tiles. This selected range provides a worth while cost saving, whilst maintaining system performance.





**Canal Engineering Ltd**

Lenton Lane, Nottingham NG7 2PQ

Tel: 0115 986 6321

Fax: 0115 986 0211

email: [sales@canalengineering.co.uk](mailto:sales@canalengineering.co.uk)

web: [www.canalengineering.co.uk](http://www.canalengineering.co.uk)